



Project _____

Item No. _____

Quantity _____

ER88

Easy Rail Electric Refrigerated Prep Table

Model Available

- ER88 - 88" wide, 3 door prep table with stainless steel rail and work top

Refrigeration System

- Factory engineered, self-contained, capillary tube system using environmentally friendly (CFC free) R404A refrigerant
- Evaporator coil & condenser balanced for low power consumption - holding the widest temperature range in its class and getting the best in food preservation
- Coolers adjustable from 32 to 50°F (0°C to 10°C)
- Sealed, cast iron, self-lubricating evaporator fan motor(s) and larger fan blades with a more efficient low velocity, high volume airflow design

Construction

- Higher insulation rates thanks to high-tech environmentally friendly CFC free, cyclopentane foaming insulation.
- Coved corners or easy cleaning
- Stainless steel exterior and interior
- Door extends full width of cabinet shell
- Self closing hinged magnetic doors
- Magnetic gasket of one piece construction, removable without tools for ease of cleaning



Standard Features

- Three heavy duty PVC coated wire 18" x 26" rack included
- Warranty: 1 year parts and labor, 5 year compressor

Options & Accessories

(AT ADDITIONAL CHARGE)

- 18" x 26" stainless steel wire rack

SHORT FORM SPECIFICATIONS: Provide Marsal model ER88 refrigerated prep table. Unit shall feature CFC free, cyclopentane foaming insulation. Two doors extend the full width of the cabinet shell with self closing hinged magnet doors and a magnetic gasket that is removeable without tools. The unit includes a stainless steel work top. The refrigeration system is self-contained and CFC free. The evaporator coil and condenser are balanced for low power consumption. Unit is adjustable from 32 to 50°F (0°C to 10°C). Unit shall have sealed, cast iron, self-lubricating evaporator fan motor(s) and larger fan blades with a more efficient low velocity, high volume airflow design. Provide with eighteen month oven parts and one year labor warranty. Provide with options and accessories as indicated.

DIMENSIONS ARE IN INCHES [MM]

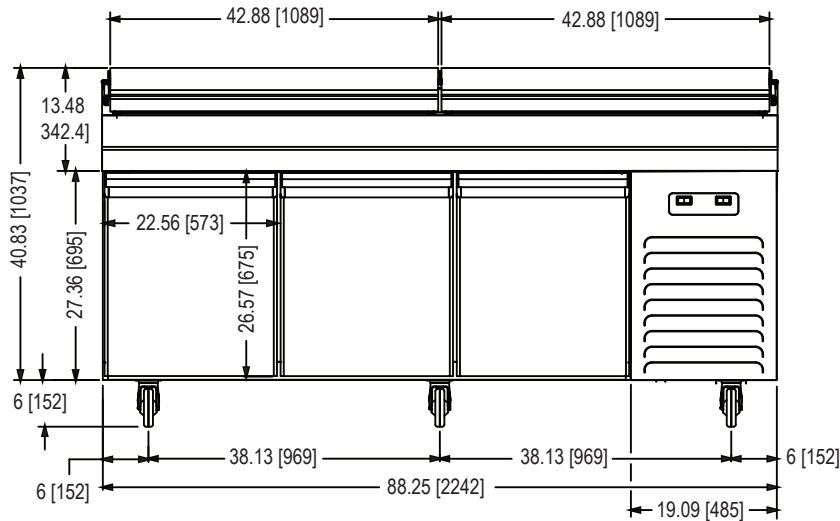

FRONT VIEW

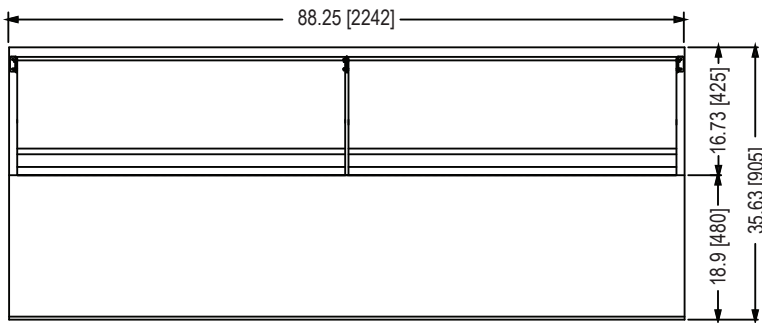

TOP VIEW

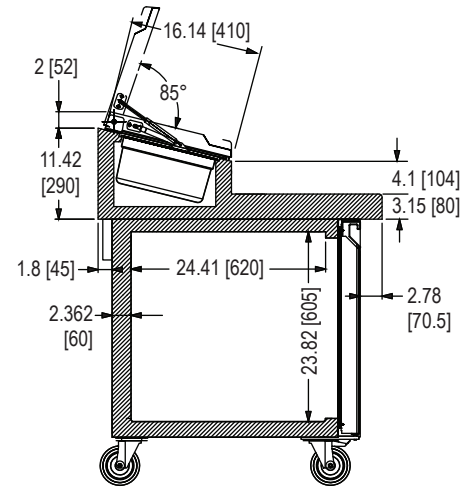

SIDE VIEW SECTION

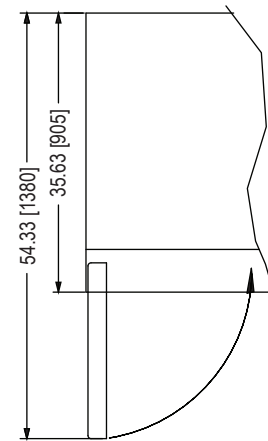

TOP VIEW W/OPEN DOOR

Specifications

Dimensions	88.25" W x 35.63" D x 46.83" H (2242x 905 x 1189 mm)
Capacity	22 cubic feet
Rack capacity*	Twelve 18" x 26" racks
Electrical	115 / 60Hz / 1Ph / 8 amp
Refrigerant type	Environmentally friendly (CFC free) R404A
Warranty	1 year parts and labor, 4 additional year compressor (parts only)
Shipping weight	462 lbs (210 kg)

* Ships with 3 racks, additional racks available as an accessory



Copyright 2017 Marsal . All designs and specifications presented in this document are subject to change without notice due to constant innovation.